



Developers :
OCEAN SMART SPACE

Site : **Darshanam Ocean**
Behind Gotri Police Station,
Beside Surya Villas Society,
Gotri-Vasna 30 Mtr. Road,
Gotri, Vadodara - 390021

M: +91 74860 40308
E: ocean@darshanam.co.in
W: www.darshanam.co.in

Architect :



Structure
**ASHOK SHAH
& ASSOCIATES**

QR CODE FOR
LOCATION



QR CODE FOR
WEBSITE



RERA NO :
PR/GJ/VADODARA/ VADODARA/
Others/RAA09909/190322

www.gujrera.gujarat.gov.in



**REFLECTION
OF PERFECTION**



IN THE
OCEAN OF
MEMORIES
LIE THE
WAVES OF
OUR
MOMENTS

Come and dwell in spaces that embrace your senses with the joys of little pleasures of life. Inspired by nature, Darshanam ocean offers you finest spaces to live a life of abundance and experience the depths of happiness, just like the ocean.

SURF
THROUGH
THE
GOODNESS
OF LIFE



MAKING WAVES ACROSS VADODARA'S REAL ESTATE SHORES

For almost a quarter of a century, Darshanam Group has been transforming the concept of luxury living. With a vision of enhancing lives, the Group has been designing spaces that are a superior blend of value and premium lifestyle, which has not only made luxury affordable but also improved the quality of life in Vadodara.

Since inception, the Group has been consistent in offering varied lifestyle designs at greater values in the most desirable communities. The Group's ability to foresee industry and lifestyle changes, technical prowess, pre-construction know-how and self-performance capability, enables it to develop solutions that exceed expectations and deliver award winning projects.



ARCHITECTS WITH A VISION BEYOND THE OBVIOUS

At Darshanam Group, our success mantra has always been to redefine industry trends by raising benchmarks. We always look for innovative ways to enhance the quality of lives of our customers. Our commitment to unmatched quality, excellent customer service, exceptional value and on-time delivery ensures that we deliver happiness in our every project.



YOUR LIGHTHOUSE OF ACCESSIBILITY

Homes are always about comfort and accessibility. With the number of properties multiplying with each passing year, you often end up choosing comfort over accessibility or the other way around. Not anymore. Stay connected to the world, minus the humdrums.

A location that is in the heart of the city, quite in literal sense, Darshanam Ocean is close to the best of public utilities, malls, multiplexes, educational institutes and everything that you need in your day-to-day life.



I ♥ VADODARA

A cultural capital where you can set the pace of your lifestyle, Vadodara, popularly known as the 'Banyan City' nestles cosmopolitan citizens which reflects in its rich cultural heritage and landmarks like the Lukshmi Vilas Palace, Sur Sagar, Kirti Mandir, MS University – Monuments that narrate a multitude of stories.



YOUR GATEWAY TO ELEGANT LIFESTYLE

The moment you enter Darshanam Ocean, you feel the aura of the vicinity that engulfs your senses with its tranquility. An open-armed welcome for an ocean of amenities that await you in its premises.



Elegant Entrance Gate



CCTV System

PEARLS OF ARCHITECTURAL MARVELS

Darshanam Ocean is where the sails of your dreams find the shores of reality. Each home has been meticulously designed in a way that they complement with your lifestyle and become extensions of your personality.



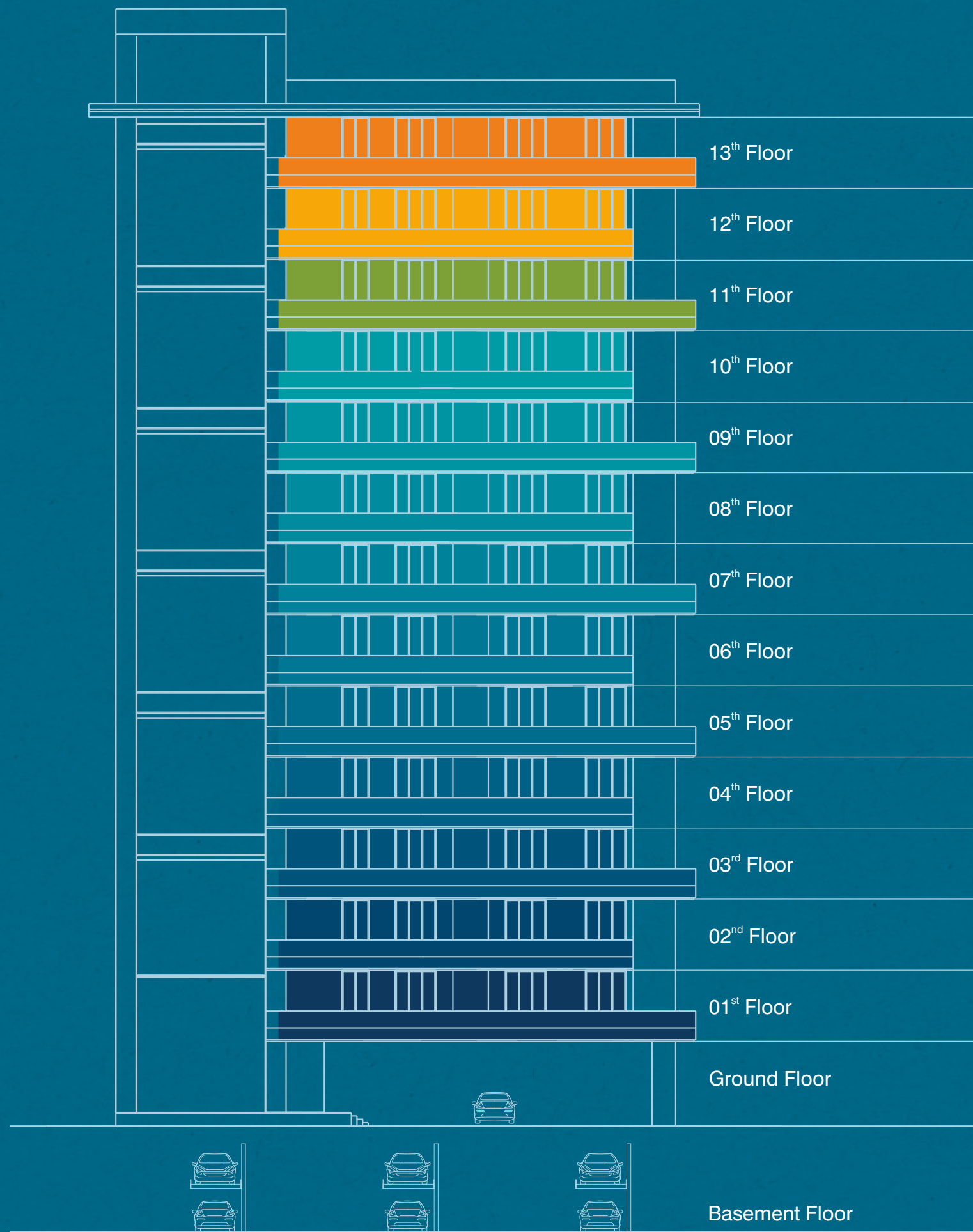

SHORES OF ULTIMATE OPULANCE

Stunning Aesthetics

Luxurious Residences

Best In Class Amenities

Panoramic Views For A Lifetime

Green-scapes Around Your Home

Prime Location In The City

Vastu Compliant

Affordability

Great Ventilation

Complete Privacy

Balcony With Green Spaces

All Bedrooms With Attached Toilet

Automatic Passenger Lifts

Ample Parking With Decorative Paving

Stand-by Generator For Common Amenities Power Backup

Modern Fire Fighting System

Multi-band Security System (Gated Security, Intercom)

Provision For AC Outdoor Unit

Hydraulic Parking Provision

At Darshanam Ocean, the amenities aren't just add-ons, but value addition to your day-to-day life. Thoughtfully designed, each amenity becomes part of your lifestyle, right from the swimming pool, kids play area, indoor games at the clubhouse or the open wide spaces that embrace the bounties of nature, making a simple walk something to cherish.

WAVES
THAT VIBE
WELL WITH YOU



Elegant Foyer

Waiting Area

Reception Area

A warm smile greets you every time you visit us at Darshanam Ocean, apart from a friendly assistance being just a call away from you, thanks to a dedicated reception at the entrance of our premise.



YOUR
VIEWS OF
WONDER







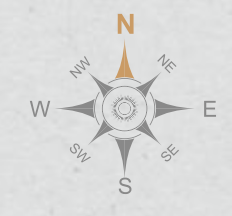

BASEMENT FLOOR LAYOUT

01	Lift	6'0"x8'0"
02	Lift	6'6"x8'6"
03	U.G. Tank	----
04	Pump Room	----
05	Way Down To Basement	----
06	Drive Way	----

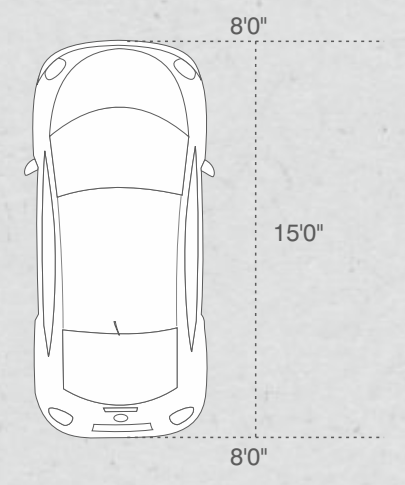



GROUND FLOOR LAYOUT

01	Entry	----	18	Admin Room	11'0"x20'3"
02	Foyer	41'3"x15'6"	19	Kid Zone	28'9"x20'3"
03	Gym	47'6"x35'6"	20	Library	12'0"x23'6"
04	Garden	----	21	Indoor Games	27'9"x23'6"
05	Zumba/Yoga	21'6"x35'3"	22	Toilet (her)	8'0"x13'0"
06	Swimming Pool	45'0"x38'0"	23	Toilet (his)	12'0"x10'0"
07	Splash Pool	14'0"x14'0"	24	Pool	36'3"x23'6"
08	Deck	----	25	Café Area	19'0"x14'0"
09	Changing Room (Her)	10'6"x16'0"	26	Lift	6'0"x8'0"
10	Changing Room (His)	10'6"x16'0"	27	Lift	6'6"x8'6"
11	Disco Theque	24'0"x40'0"	28	Way Down To Basement	----
12	Foyer	16'9"x26'6"	29	Open Chess	----
13	Multipurpose Hall	24'0"x48'6"	30	Water Body	----
14	Passage	----	31	Jogging Track	----
15	Home Theatre	48'6"x25'0"	32	Gazebo	----
16	Foyer	26'6"x16'9"	33	Garden Sitting	----
17	Passage	8'0"x31'3"	34	Allotted Car Parking	----

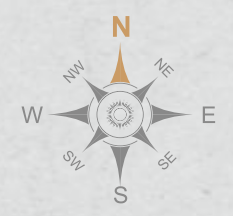

TYPICAL FLOOR PLAN

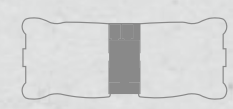

Each Floor
2 Flats



2 Lifts Between
2 Flats

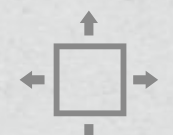

Four Side
Open Flats



No Common Wall
between Flats

YOUR ADDRESS OF TRANQUILITY

When you stay at Darshanam Ocean, you can always be sure of the finest amenities that you have always looked for and a way to spend quality time with your loved ones and make new friends who happen to be your neighbours.



Attractive Space



Tower A
TYPICAL FLOOR PLAN
1st, 3rd, 5th, 7th, 9th, 11th, 13th

- Unit Space
- Balcony Space
- Standing Balcony | Flower Bed

Tower A | 4BHK
101-301-501-701-901-1101-1301
Balcony | 19'3"x5'0"
Standing Balcony | Flower Bed



Tower A
TYPICAL FLOOR PLAN
1st, 3rd, 5th, 7th, 9th, 11th, 13th

Tower A | 4BHK
102-302-502-702-902-1102-1302
Balcony | 5'0"x14'0"
Standing Balcony | Flower Bed

- Unit Space
- Balcony Space
- Standing Balcony | Flower Bed



Tower A
TYPICAL FLOOR PLAN
2nd, 4th, 6th, 8th, 10th, 12th

- Unit Space
- Balcony Space
- Standing Balcony | Flower Bed



Tower A | 4BHK
201-401-601-801-1001-1201
Balcony | 19'3"x5'0"
Standing Balcony | Flower Bed



Tower A
TYPICAL FLOOR PLAN
2nd, 4th, 6th, 8th, 10th, 12th



Tower A | 4BHK
202-402-602-802-1002-1202
Balcony | 5'0"x14'0"
Standing Balcony | Flower Bed

- Unit Space
- Balcony Space
- Standing Balcony | Flower Bed

Tower B

TYPICAL FLOOR PLAN

1st, 3rd, 5th, 7th, 9th, 11th, 13th



Tower B | 4BHK

102-302-502-702-902-1102-1302

Balcony | 5'0"x19'6"

Standing Balcony | Flower Bed



Tower B

TYPICAL FLOOR PLAN

2nd, 4th, 6th, 8th, 10th, 12th



Tower B | 4BHK

202-402-602-802-1002-1202

Balcony | 5'0"x19'6"

Standing Balcony | Flower Bed



Tower C-D

TYPICAL FLOOR PLAN

1st, 3rd, 5th, 7th, 9th, 11th, 13th



Tower C&D | 4BHK

101-301-501-701-901-1101-1301

Balcony | 5'0"x19'6"

Standing Balcony | Flower Bed



Tower C-D

TYPICAL FLOOR PLAN

2nd, 4th, 6th, 8th, 10th, 12th

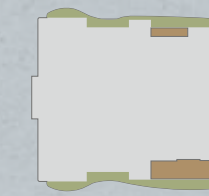

Tower C&D | 4BHK

201-401-601-801-1001-1201

Balcony | 5'0"x19'6"

Standing Balcony | Flower Bed





WATER THAT SPLASH UP JOYS



Swimming Pool



Deck Seating



Splash Pool



Changing Room



YOUR OWN
CRUISE OF LUXURY



YOUR
'NIGHT' IN
SHINING ARMOUR



YOUR
SPACE TO
LOUNGE AROUND



YOUR
SPACE OF
INNER PEACE





YOUR FAVOURITE HANGOUT SPOT



Attractive Water Body



Captivating Plantation



Garden Sitting Area

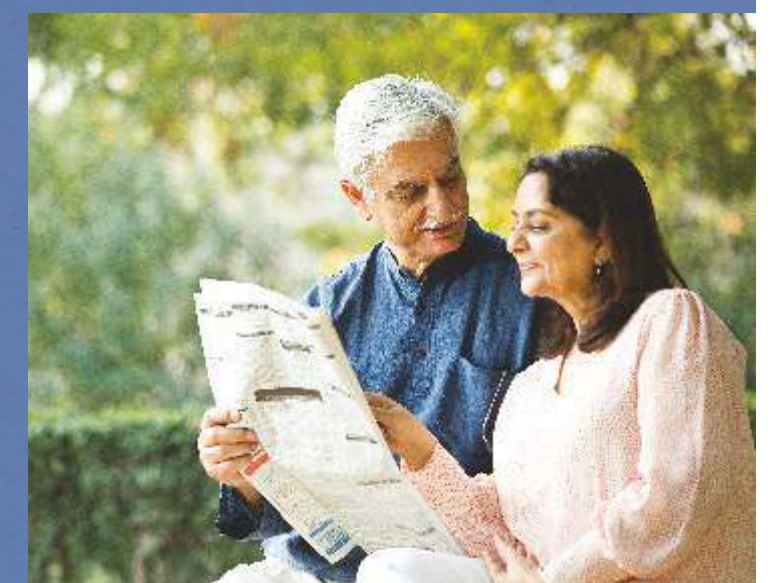

SPLASH INTO A
WHOLE NEW WORLD
OF OPULENCE



Lovely Gazebo



Jogging Track



Children's Play Area



Landscape Garden



Café Area



Open To Sky Yoga / Aerobic Zone



Multipurpose Hall

YOUR
MOMENTS
OF SOLITUDE





GYMNASIUM

Well-equipped
for your fitness



LIBRARY

Well-stocked for
your wisdom



POOL ROOM

Well-spaced
for your leisure



GAME ROOM

Well-designed
for your competitions



BANQUET

Well-crafted for
your celebrations



DISCOTHEQUE

Well-themed
for your parties

YOUR
PLAYGROUND
OF JOYS





Indoor Children's Play Room



Out Door Children's Play Area

YOUR PLAYSCHOOL OF INNOCENCE

At Darshanam Ocean, childhoods thrive amid the sunshine of good cheer. Each nook and corner of our homes have been thoughtfully designed to delight the toddlers of your house,

ensuring that their growing up years is replete with wonderful memories.



SPECIFICATION

STRUCTURE

- RCC Earthquake Resistance Structure Designed By Approved Structure Engineer

FLOORING

- Premium Vitrified Flooring In Guest Lounge, Kitchen And Dining Area
- Wooden Flooring In Master Bedroom
- Vitrified Tiles In All Other Bed Rooms
- Anti-skid Flooring In Balcony & Wash

WALL FINISH

- Interior: 2-coat Putty With Primer Finish
- Exterior: Weather Proof Paint

ELECTRICAL

- Concealed Copper ISI Wire With Modular Switches And Sufficient Electrical Points

TERRACE

- Elegant China Mosaic Finish With Water Proofing Treatment.

KITCHEN

- Granite Platform And SS Kitchen Sink. Wash Area With Ceramic Tile Dado & Natural Stone/ Anti-skid Tile Flooring

DOORS

- Main Door: High Quality Wooden Frame Door With Veneer / Shine Laminate Paneling On Both Sides
- Other Internal Doors: Wooden Frames/ Stone Frame Laminated Flush Doors

WINDOWS

- Colour Anodized Aluminium/ UPVC Sliding Windows

TOILET

- Designer Bathrooms With Premium Quality Fittings & Vessels. Glazed Tile Dado Upto Door Height.



YOUR
TOWER
OF PRIDE



Payment Terms:

- 30% Booking amount Incl. Token
- 10% On Plinth Level
- 4% x 12 = 48% On Each Slab Level
- 4% On Plaster Level
- 4% On Flooring Level
- 4% Before Possession

We Request:

(1) Maintenance Deposit, Document Charges, MGVCL Deposit and Municipal Charges to be paid extra. (2) Any External changes in elevation shall not be permitted. Additional work (if any) will be carried out after receiving full payment in advance. (3) Possession will be given after one month of settlement of all dues. (4) In case of delayed payment 24% interest will be charged & continuous default payments lead to cancellation. (5) In case of cancellation of booking the refundable amount shall be given only when the same property is booked and paid for by the new purchaser. Administration charges of 10% of the booking amount and the amount of extra work done (if any) shall be deducted from the refund. (6) All municipal taxes shall be the responsibility of the customer after the date of the booking. (7) Any delay of corporation activity shall be unilaterally faced.

Disclaimer:

All the content mentioned in this document is tentative and subject to variation at the sole discretion of the Company and/or the promoters. Visual references are purely conceptual and the brand names featured in them are for reference only. The Developers reserve the full right to alter design, plans or specifications where required or deemed necessary without any intimation or reason.